

# •• MAXBlend™

OPERATING MANUAL &  
INSTRUCTIONS FOR USE

R203P05-001







Maxtec  
 6526 South Cottonwood Street  
 Salt Lake City, Utah 84107  
 USA

TEL (800) 748.5355  
 FAX (801) 270.5590  
 www.maxtecinc.com

Authorized Representative:



QNET BV  
 Hommerterweg 286  
 6436 AM Amstenrade  
 The Netherlands



Read this entire manual before attempting to operate or service the MAXBlend™. Attempting to operate the MAXBlend™ without fully understanding its features and functions may result in unsafe operating conditions.

**CLASSIFICATION**

Classification: . . . . . Internally Powered  
 Protection against electric shock: . . . . . Type B applied Part.  
 Mode of Operation: . . . . . Continuous  
 Sterilization: . . . . . See section 5.0  
 Flammable anesthetic mixture: . . . . . Not suitable for use in presence of a flammable anesthetic mixture

**Power Specifications:**

3V = 21 mW 7mA(max)



**Product Disposal Instructions:**

The sensor, batteries, and circuit board are not suitable for regular trash disposal. Return sensor to Maxtec for proper disposal or dispose according to local guidelines. Follow local guidelines for disposal of other components

## **WARRANTY**

### **THE MAXBlend™ IS WARRANTED TO BE FREE FROM DEFECTS IN MATERIAL AND WORKMANSHIP AND TO MEET THE PUBLISHED SPECIFICATIONS FOR TWO (2) YEARS .**

Maxtec® oxygen sensors are designed for medical oxygen delivery equipment and systems. Under normal operating conditions Maxtec® warrants new oxygen sensors to be free from defects of workmanship and materials for their designated warranty period of one (1) years from date of shipment from Maxtec, provided that the sensor is properly installed and operated.

Maxtec®'s sole obligation under this warranty is limited to making sensor replacements or issuing credit for sensors found to be defective by Maxtec®. This warranty extends only to the buyer purchasing the sensor directly from Maxtec® or through Maxtec®'s designated distributors and agents as new equipment. Should a sensor fail prematurely, the replacement sensor is warranted for the remainder of the original sensor warranty period.

Maxtec® and any other subsidiaries or affiliates shall not be liable to the buyer or other persons for incidental, consequential damages or sensors subject to abuse, misuse, misapplication, alteration, negligence or accident.

The MAXBlend™ monitor is designed for medical oxygen delivery equipment and systems. Under normal operating conditions, Maxtec® warrants the MAXBlend™ monitor to be free from defects of workmanship or materials for a period of two (2) years from the date of shipment from Maxtec®, provided that the unit is properly operated and maintained in accordance with Maxtec®'s operating instructions. Maxtec®'s sole obligation under this warranty is to repair, replace, or issue credit for equipment found to be defective.

This warranty extends only to the buyer purchasing the equipment directly from Maxtec® or through Maxtec®'s designated distributors and agents as new equipment.

Routine maintenance items, such as batteries, are excluded from warranty. Maxtec®, and any other subsidiaries or affiliates shall not be liable to the buyer or other persons for incidental, consequential damages or sensors subject to abuse, misuse, misapplication, alteration, negligence or accident.

THESE WARRANTIES ARE EXCLUSIVE AND IN LIEU OF ALL OTHER WARRANTIES, EXPRESSED OR IMPLIED, INCLUDING WARRANTY OF MERCHANTABILITY AND FITNESS FOR A PARTICULAR PURPOSE.

## **EMC Notice**

This equipment generates, uses, and can radiate radio frequency energy. If not installed and used in accordance with the instructions in this manual, electromagnetic interference may result. The equipment has been tested and found to comply with the limits set forth in IEC 60601-1-2 for Medical Products. These limits provide reasonable protection against electromagnetic interference when operated in the intended use environments described in this manual.

## **MRI Notice**

This equipment contains electrotronic and ferrous components whose operation can be affected by intense electromagnetic fields. Do not operate the MAXBlend™ in an MRI environment or in the vicinity of high-frequency surgical diathermy equipment, defibrillators, or shortwave therapy equipment. Electromagnetic interference could disrupt the operation of the MAXBlend™.

## ⚠ WARNINGS

Indicates a potentially hazardous situation, if not avoided, could result in death or serious injury.

**The following warnings apply any time you operate or service the MAXBlend™:**

- » **To avoid explosion, do not operate the MAXBlend™ in the presence of flammable anesthetics or in an atmosphere of explosive gases. Operating the MAXBlend™ in flammable or explosive atmospheres may result in fire or explosion.**
- » DO NOT operate the MAXBlend™ unless qualified personnel are in attendance to promptly respond to alarms, inoperative conditions, or sudden malfunctions. Patients on life-support equipment should be visually monitored at all times.
- » DO NOT ignore audible alarms of the MAXBlend™. Alarms indicate conditions that require your immediate attention.
- » DO NOT use parts, accessories, or options that have not been authorized for use with the MAXBlend™. Using unauthorized parts, accessories, or options may be harmful to the patient or damage the MAXBlend™.
- » Check all audible and visual alarms daily to make sure they are operating properly. If an alarm fails to activate, contact your Maxtec Certified Service Technician.
- » Consult a physician to determine concentration of inspired oxygen to be delivered.
- » **DO NOT operate the MAXBlend™ without setting the adjustable alarms. All adjustable alarms must be set to ensure safe operation.**
- » Explosion hazard. DO NOT gas sterilize the MAXBlend™.
- » DO NOT steam autoclave or otherwise subject the MAXBlend™ to temperatures above 122°F (50°C).
- » If the air or oxygen gas source fails, the pressure differential alarm will sound alerting the clinician that a condition has occurred that may significantly alter the FiO<sub>2</sub> and flow output from the MAXBlend™.
- » If either the air or oxygen source pressure is reduced or increased sufficiently to create a pressure differential of 20 PSI or more, an audible alarm will sound. This condition may significantly alter the FiO<sub>2</sub> and flow output from the MAXBlend™.
- » DO NOT use humidified oxygen to calibrate this system. If calibrated with humidified oxygen, subsequent oxygen readings will be higher than the true oxygen level.
- » DO NOT tape, obstruct or remove the reed alarm during clinical use.
- » DO NOT occlude the sensor port on the side of the MAXBlend™.
- » DO NOT routinely disconnect or remove O<sub>2</sub> sensors from the MAXBlend™. If the sensor must be disconnected, the full “warm-up” period, as stated in the sensor specifications, may be required after the sensor is reconnected.
- » The mixed gas bleed continuously bleeds to atmosphere at the oxygen concentration setting of the control knob. Bleeding oxygen into any closed area could increase the risk of fire or explosion. Do not operate this device in the presence of any flame or source of ignition; or when using equipment such as electrosurgical equipment or defibrillators.
- » Consult a physician for appropriate FiO<sub>2</sub> settings.
- » An air inlet/water filter is recommended for use with the MAXBlend™.
- » If the MAXBlend™ does not function as described in Section 2, contact your Maxtec Distributor. Do not use the MAXBlend™ until correct performance has been verified.
- » Galvanic O<sub>2</sub> sensor electrolyte gel may be acidic and may cause skin or eye irritation and/or burns. Take care when handling or replacing exhausted or damaged disposable O<sub>2</sub> sensors. Be sure to dispose of expired sensors in accordance with hospital and/or governmental regulations. (O<sub>2</sub> Sensor MSDS upon request Maxtec®, Phone: (801) 266-5300)
- » Do not operate the MAXBlend™ unless qualified personnel are in attendance to promptly respond to alarms, inoperative conditions, or sudden malfunctions.
- » The MAXBlend™ low flow blender has been manufactured with a low alarm setting adjustable down to 15%. This change is within the guidelines set forth in ASTM Specification 1462-93. The MAXBlend™ is labeled to indicate this feature. This feature is not in conformance with IEC 21647.

- » This device has not been tested in presence of gases other than air and/or oxygen.
- » If a condition is detected that could possibly prevent the blender from continuing to operate safely, it will sound an alarm. If at any time, Erx is displayed (i.e. Er1, Er4, etc.) appears on the LCD. Contact a Maxtec certified service technician.
- » There are no user serviceable components inside this device. All service should be referred to a Maxtec® trained hospital/dealer service technician or Maxtec®.
- » Elastomer components such as O-rings are designed to function satisfactorily for a minimum of two (2) years. Maxtec® recommends that the MAXBlend™ be overhauled and serviced at a minimum of every two (2) years under the best circumstances.
- » If the MAXBlend™ is dropped, follow the procedures outlined in Chapter 3 for a Performance Check before reusing the device.
- » Always remove the batteries to protect the unit from potential leaky battery damage when the unit is going to be stored (not in use for 1 month) and replace dead batteries with recognized name brand AA Alkaline batteries.

### **CAUTION:**

Indicates a potentially hazardous situation, if not avoided, could result in minor or moderate injury and property damage.

- » Do not store the MAXBlend™ in hot areas for prolonged periods of time. Temperatures above 80°F (27°C) can shorten battery life.
- » To minimize the potential for electrostatic shock, do not use antistatic or electrically conductive hoses with the MAXBlend™.
- » The use of oxygen sensors not produced specifically for use with the MAXBlend™ may result in performance that does not conform to stated specifications in this manual. MAXTEC® RECOMMENDS THE MAX250E SENSOR WITH THE MAXBLEND™.
- » Do not clean or dry the MAXBlend™ with a high pressure air gun. Applying high pressure air to the MAXBlend™ may damage components and render the system inoperable.
- » Do not over clean the MAXBlend™. Repeated use of a cleaning agent can cause residue buildup on critical components. Excessive residue buildup can affect the MAXBlend's performance.
- » When cleaning the MAXBlend™: Do not use harsh abrasives. Do not immerse the MAXBlend™ in liquid sterilizing agents or liquids of any kind. Do not spray cleaning solution directly onto the front panel, sensor port or bleed muffler. Do not allow cleaning solution to pool on the front panel, sensor port or bleed muffler.
- » Do not sterilize the MAXBlend. Standard sterilization techniques may damage the blender.
- » If the MAXBlend™ does not function as outlined in Chapter 2, contact a Maxtec® trained service technician or Maxtec® for service.
- » Do not attempt to clean the MAXBlend™ with cleaning agents that contain phenols, ammonia chloride, or chloride compounds, or that contain more than 2% glutaraldehyde. These agents may damage the plastic components and control panel overlays.
- » Dropping or severely jarring the sensor after calibration may shift the calibration point enough to require recalibration.
- » Using the MAXBlend™ to analyze and monitor oxygen concentrations other than at the sensor port of the unit will require recalibration of the sensor.
- » Always operate the MAXBlend™ with clean, dry medical grade gases. Contaminates or moisture can cause defective operation. Oxygen should have a minimum dewpoint of -80°F (-62°C) or moisture content less than 7.9 PPM (0.0059mg/L). Oxygen "purity" should be at least 99.6% and air used should be medical grade. Water vapor content must not exceed a dew point of 5°F (-15°C) below the lowest ambient temperature to which the delivery system is exposed. Particulate content must not exceed that which would be found immediately downstream of a 15 micron absolute filter. Refer to CGA commodity specifications G-4.3 and G7.1 for more information. Water vapor content of medical air or O2 supply to the blender must not exceed 5.63 x 10<sup>3</sup> milligrams H<sub>2</sub>O per cubic meter of non-condensable gas.
- » When disassembling, care must be exercised to prevent damaging the printed circuit board. All work must be accomplished in a static safe environment.
- » Do not use humidified oxygen to calibrate this system. If calibrated with humidified oxygen, subsequent oxygen readings will be higher than the true oxygen level.

- » Variations in inlet gas source pressures will alter the accuracy of the oxygen readings of the MAXBlend™.
- » Using the MAXBlend™ to analyze and monitor oxygen concentrations other than at the sensor port of the unit will require recalibration of the sensor.
- » If the MAXBlend™ does not function as outlined in Chapter 2, contact a Maxtec® trained service technician or Maxtec® for service.
- » Be sure the MAXBlend™ is securely mounted. This device is usually mounted to a hospital rail system or an infusion stand. Dropping the device may cause injury or device damage.

**NOTES:**

Indicates supplemental information to assist in use of the device.

- » The MAXBlend™ is tested for compliance with ISO 11195: 1995, clause 6, and meets requirements regarding reverse gas flow as delivered.
- » Applicable parts used in the MAXBlend™ have been cleaned and degreased for oxygen service. Any lubricants used are designed specifically for the application. Do not use anything other than Maxtec® specified lubricants when servicing the MAXBlend™.
- » As long as the total pressure of the gas mixture being monitored is constant, the MAXBlend™ will accurately read oxygen concentrations. However, if the total pressure varies the reading will fluctuate proportionately as the sensor actually measures the partial pressure of oxygen in the mixture. The sensor readings will also change proportionately with barometric pressure changes. Because of this, daily calibration of the sensor is recommended.
- » Users are advised to use pressure regulators, set to 50±5 PSIG(3.4± .4 BAR), which display system pressure.
- » All specifications assume the following standard environmental conditions, unless specified otherwise. Ambient and sample gas temperatures of 77°F (25°C); barometric pressure of 30:Hg (760mmHg); sea level altitude; ambient relative humidity of 50%; sample gas relative humidity of 0%.
- » It is important to note that the oxygen concentration selection scale is provided only as a guideline for selecting O<sub>2</sub> concentrations. The clinician should use the MAXBlend's display panel to adjust the O<sub>2</sub> concentration to the desired setting.

## ❖ TABLE OF CONTENTS

Classification .....	I
Warranty .....	II
Warnings .....	II
1.0 Introduction .....	1
1.1 Intended Use .....	1
1.2 Disposable Galvanic O <sub>2</sub> Sensor .....	2
1.3 Symbol Guide .....	2
1.4 Front Panel Functional Description .....	2
1.5 Back View .....	5
1.6 What You Will Need to Operate the Blender .....	6
2.0 Operating Procedures .....	6
2.1 Setup and Installation .....	6
2.1.1 Battery Installation .....	6
2.1.2 MAXBlend™ Setup .....	6
2.1.3 Sensor Installation .....	6
2.2 Monitoring .....	7
2.3 Device Set-up .....	7
2.3.1 Low Alarm Setting .....	7
2.3.2 High Alarm Setting .....	7
2.4 Basic Operation .....	8
2.5 Alarms and Conditions .....	8
2.6 Calibration Procedures .....	8
2.6.1 100% Oxygen Calibration .....	8
2.6.2 Calibration to Room Air .....	10
2.6.3 Automatic Calibration to a Known Concentration .....	10
3.0 Performance Check .....	11
3.1 Pressure Differential Alarm/Bypass Check .....	11
4.0 TROUBLESHOOTING .....	12
4.1 Problem Troubleshooting .....	12
5.0 CLEANING THE MAXBlend™ .....	14
6.0 SERVICE AND MAINTENANCE .....	14
6.1 Maintenance .....	14
6.2 Replacing the O <sub>2</sub> Sensor .....	14
6.3 Service Procedure .....	14
7.0 ABBREVIATION GUIDE .....	15
8.0 SPECIFICATIONS .....	16
8.1 Low Flow Instrument Specifications .....	16
8.2 Alarm Specifications .....	16
8.3 O <sub>2</sub> Sensor Specifications .....	16
9.0 FACTORS INFLUENCING CALIBRATION .....	17
9.1 Temperature Effect .....	17
9.2 Pressure Effect .....	17
9.3 Humidity Effect .....	17
9.4 Routine Maintenance .....	17
10.0 SPARE PARTS AND ACCESSORIES .....	18
11.0 THEORY OF OPERATION .....	19
9.1 Operational Diagram .....	19
9.2 Mixing Operation .....	19
9.3 Gas Outlet .....	19
9.4 Alarm/Bypass Function .....	20
12.0 FLOW CHARACTERISTICS .....	20



## » 1.0 Introduction

The MAXBlend™ is a compact air/oxygen gas mixing device which incorporates the use of a battery powered oxygen monitor. The gas mixing device (blender) provides precise mixing of medical grade air and oxygen, while the monitor measures the selected oxygen concentrations from the blender's gas flow and samples and displays these measured concentrations on a digital display. The monitor provides high and low alarm limits which, when exceeded, cause an audible and visual alarm.

The MAXBlend™ design allows for a wide scope of applications including:

- » Free-flow oxygen administration
- » Mechanical ventilation of adults, pediatrics, and neonates
- » Continuous Positive Airway Pressure (CPAP)

### 1.1 Intended Use

The MAXBlend™ is designed to provide a continuous air/oxygen gas mixture to infant, pediatric, and adult patients. It is a restricted medical device intended for use by qualified, trained personnel, under the direction of a physician, in institutional environments where the delivery and monitoring of air/oxygen mixtures is required.

### 1.2 Disposable Galvanic O<sub>2</sub> Sensor

The sensor is a galvanic, partial pressure sensor that is specific to oxygen. It consists of two electrodes (a cathode and an anode), a teflon membrane and electrolyte. Oxygen diffuses through the teflon membrane and immediately reacts at a gold cathode. Oxygen ions are transported in the electrolyte solution to a lead anode where oxidation occurs, generating an electrical current. Since the sensor is specific to oxygen, the current generated is proportional to the amount of oxygen present in the sample gas. When no oxygen is present, there is no chemical reaction and therefore, no current is produced. In this sense, the sensor is self-zeroing.

### 1.3 Symbol Guide

The following symbols and safety labels are found on the MaxBlend™:



Attention, consult accompanying documents



Manufacturer



Evaluated by ETL  
(Intertek Testing Laboratories)



Serial Number



Do not throw away. Follow local guidelines for disposal.

LPM Liter per minute flow



Lot code/Batch code

LOW BAT Low Battery

Rx only Use by prescription only



Type B applied part  
conforms to IEC 60601-1











Catalog Number



Authorized Representative  
in the European Community

### 1.4 Front Panel Functional Description (see page 4 for diagram)

- (A) Display-** A digital liquid crystal display provides direct readout of oxygen concentrations in the range of 0% to 100%. It also displays CAL when the calibration mode is entered.
- (B) Battery Low Indicator-** The low battery indicator appears on the LCD display when the power supply voltage drops below acceptable limits. When LOW BAT icon is visible, batteries should be replaced.
- (C) % Sign-** The percent sign indicates when the unit is locked or unlocked and when the unit is calibrating.
- (D) Power ON/OFF Key-**  This key is used to turn on or off the monitor. The blender will continue to function and deliver mixed gas with display turned to OFF.
- (E) Lock Key-**  Pressing the LOCK key will unlock the keypad and cause the LOCKED icon to disappear from the LCD readout. The MAXBlend™ can then be calibrated and alarm settings can be changed if desired. If no other keys are pressed within 10 seconds, the LOCKED icon will reappear and the unit will revert to the LOCKED mode. When the unit is in the unlocked state, pressing the LOCK key will also cause the LOCKED icon to reappear.
- (F) Calibrate Key-**  When the keypad is unlocked, the CAL key is used in conjunction with the up and down keys to calibrate the MAXBlend™.

- G Up and Down Keys-**   The up and down arrow keys are used to adjust alarm settings or to calibrate the MAXBlend™.
- H LOW SET Key-**  The LOW SET key is used in setting the low FiO2 alarm limit. The device must be in the unlocked state for the key to operate. See Section 2.3.1 for instructions on setting the low FiO2 alarm limit.
- I HIGH SET Key-**  The HIGH SET key is used in setting the high FiO2 alarm limit. The device must be in the unlocked state for the key to operate. See section 2.3.2 for instructions on setting the high FiO2 alarm limit.
- J Silence Key-**  This button silences the audible alarm that sounds if the high or low alarm limit is exceeded.
- K High Alarm Visual Display** - A red indicator light which illuminates when the high alarm limit has been exceeded.
- L Low Alarm Visual Display**- A red indicator light which illuminates when the low alarm limit has been exceeded.
- M High Alarm Display**- The high alarm setting is displayed at all times just below the HIGH icon on the LCD readout. The indicated value represents the oxygen percentage at which the high alarm will be activated.
- N Low Alarm Display**- The low alarm setting is displayed at all times just below the LOW icon on the LCD readout. The indicated value represents the oxygen percentage at which the low alarm will be activated.
- O Outlet Port**- A diameter indexed (DISS) oxygen fitting which, when connected with a pneumatic metering device (such as a flowmeter) delivers the following flow: **0-30 LPM**
- P Medical Air Inlet Connector**- An air fitting for connection to an air inlet hose from the air gas source.
- Q Oxygen Inlet Connector**- An oxygen fitting for connection of an oxygen inlet hose from the oxygen gas source.
- R Oxygen Concentration Selector Control**  
A knob which allows for selections of mixed oxygen concentrations from 21% to 100%.
- S Coiled Sensor Cable**- The coiled cable connects the oxygen monitor to the MAX-250E Sensor.

**Note:** It is important to note that the oxygen concentration selection scale is provided only as a guide for selecting O<sub>2</sub> concentrations. The clinician should use the MAXBlend's display panel to adjust the O<sub>2</sub> concentration to the desired setting.

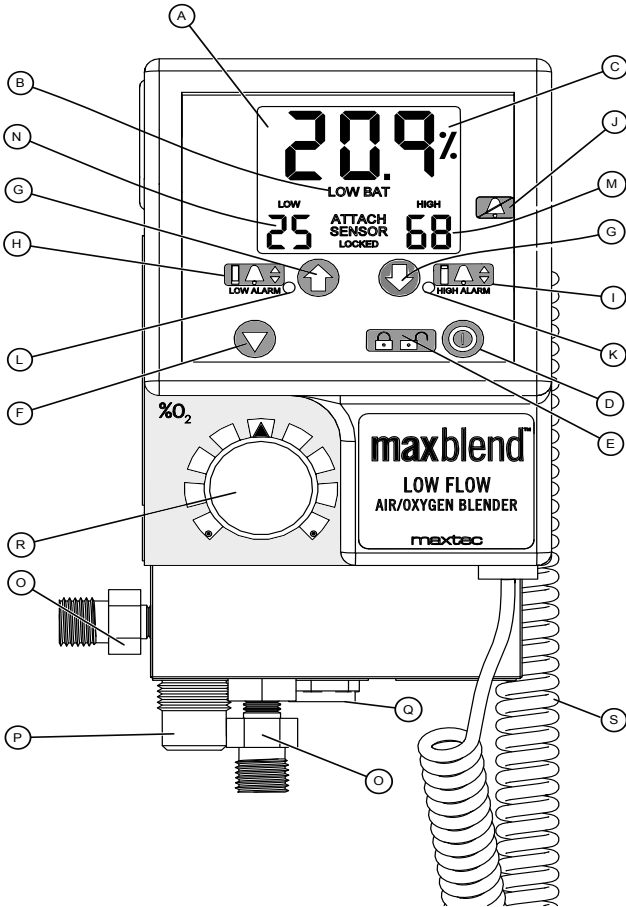

### 1.5 Back View

- (A) Dovetail Mount Adapter-** An adapter which allows the MAXBlend™ to be mounted onto a mating bracket for mounting to a rail or ventilator system.
- (B) O<sub>2</sub> Sensor Port-** A sampling port for the oxygen sensor. It allows 3 LPM of mixed gas from the blender to flow over the sensor membrane.
- (C) Pressure Differential Reed Alarm Cap-** An audible alarm which, when activated, indicates that a pressure differential of 20 PSI or more exists between the two (2) gas source pressures.

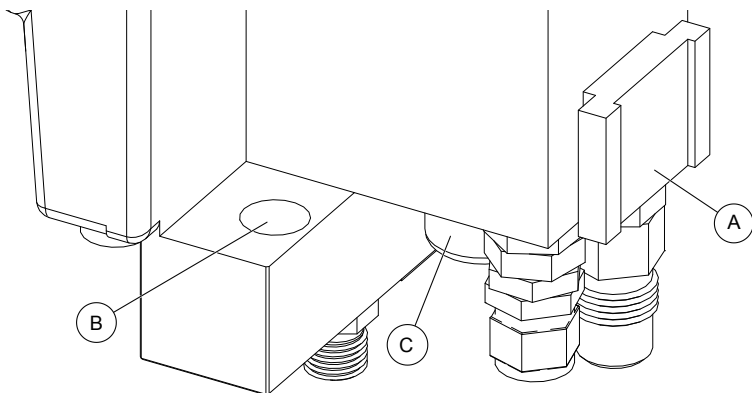

## 1.6 What You Will Need to Operate the Blender

**Pressurized Oxygen.** The compressed oxygen source must provide clean, dry, medical grade oxygen at a line pressure of 40 to 60 PSIG (2.8 to 4.2 bar).

**Pressurized Air.** The air source must provide clean, dry, medical grade air at a line pressure of 40 to 60 PSIG (2.8 to 4.2 bar).

## 2.0 Operating Procedures

### 2.1 Setup and Installation

Prior to placing the MAXBlend™ into clinical use, the performance check described in Section 3 should be performed.

#### 2.1.1 Battery Installation

Remove the battery cover located on the left side (when the screen is facing you) by inserting a slotted screwdriver (at location noted) and prying. Observing correct polarity, install two (2) standard “AA” 1.5V alkaline batteries and replace cover.

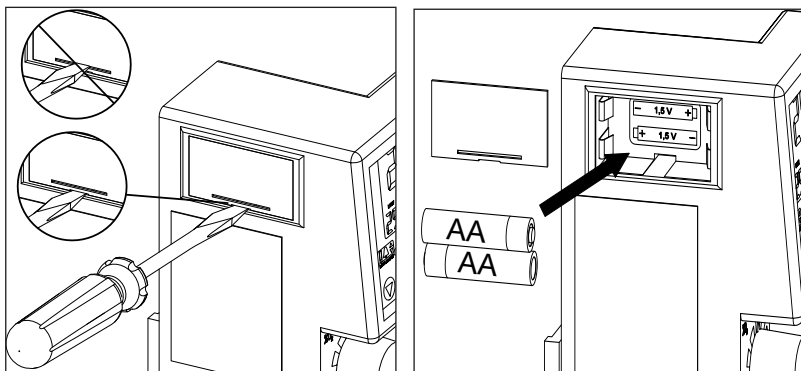

## 2.1.2 MAXBlend™ Setup

1. Connect the pressurized air source to the air inlet fitting (see pages 4-5 for location).
2. Connect the pressurized oxygen source to the oxygen fitting (see pages 4-5 for location).

## 2.1.3 Sensor Installation

1. Be sure to use a fresh O<sub>2</sub> sensor. Plug the sensor cable into the cable port on the sensor.
2. Press the ON/OFF key . Insert the sensor into the sensor port on the right side of the MAXBlend™.
3. Allow adequate time for the sensor to equilibrate to a new, ambient temperature.
4. Follow the desired calibration procedure in Section 2.6.

## 2.2 Monitoring

To begin monitoring, press the ON/OFF key  located on the front panel (if necessary). Monitoring will begin immediately.

Should oxygen level exceed either the HIGH or LOW alarm set points, the red alarm indicator on the front panel will illuminate indicating either a high or low concentration reading, and an oxygen level returns to within limits or the limits are adjusted.





To conclude monitoring, press the ON/OFF key  located on the front panel.

This will place the MAXBlend™ in a standby mode in which the display and alarm circuits are not functional, but the gas blender supply hoses will continue to supply mixed gas if the inlet hoses have not been disconnected.

## 2.3 Alarm Setting Procedure

### 2.3.1 Low Alarm Setting



To adjust the low alarm setting:



1. Press the LOCK key  to unlock the keypad.
2. Press the LOW SET key . The LOW icon will start to flash once per second.
3. Use the up  and down  arrow keys to set the low alarm to the desired value. Pressing the arrow keys changes the value in 1% increments. If the keys are held down for more than 1 second the display will scroll at a rate of 4% per second.

The low alarm value cannot be set lower than 15%, nor can it be set

closer than 1% from the high alarm value. For example, if the high alarm is set at 25%, the system will not accept a low alarm setting greater than 24%.

**Note:** If 10 seconds elapse between key actuations, the system will store the latest low alarm value and will revert to normal operation. If this occurs inadvertently, simply repeat the alarm setting procedure.





4. When the low alarm value is set, press the LOW SET  or LOCK key  again to accept the low alarm setting and return to normal operation.

**Note:** To automatically set the low alarm to 15% without scrolling the display, hold the LOW SET key down  and press the down arrow key  when the LOW icon is flashing.

**Note:** The default low alarm setting is 18% O<sub>2</sub>. Removing the batteries will reset the default alarm setting.





### 2.3.2 High Alarm Setting

To adjust the high alarm setting:

1. Press the LOCK key  to unlock the keypad.
2. Press the HIGH SET key . The HIGH icon will start to flash once per second.
3. Use the up  and down  arrow keys to set the high alarm to the desired value.

**Note:** The high alarm value cannot be set closer than 1% from the low alarm value. For example, if the low alarm is set at 50%, the system will not accept a high alarm setting less than 51%. Setting the high alarm to 100% turns off or deactivates the high alarm.

4. When the high alarm value is set, press the HIGH SET key  again to accept the high alarm setting and return to normal operation.

**Note:** To automatically set the high alarm to 50% without scrolling the display, hold the HIGH SET key  down and then press the  arrow key when the "HIGH" icon is flashing. To automatically turn off the high alarm or set it to 100%, hold the HIGH SET key  down and then press the  arrow key when the "HIGH" icon is flashing.

**Note:** The default high alarm setting is 50%. Removing the batteries will reset the default alarm setting.

## 2.4 Basic Operation

1. To check the oxygen concentration of a sample gas:
2. Place the sensor probe in the sensor port on the MAXBlend™. If using a standard T adapter in an alternate location, make sure the sensor is

mounted in the adapter with the flow diverter pointing downward. This will prevent moisture from draining into the sensor membrane.

**Note:** It is important that a tight fit exists between the probe and the T adapter.

3. Initiate flow of the sample gas to the sensor.
4. Using the ON/OFF key , make sure the MAXBlend™ is in the power on mode.
5. Allow the oxygen reading to stabilize. This normally takes about 30 seconds or more.

## 2.5 Alarms and Conditions

In the event of either a low alarm or high alarm condition, the corresponding LED will begin to flash, accompanied by the alarm buzzer. Pressing the SILENCE key  will deactivate the buzzer, but the LED and the alarm value digits on the display will continue to flash until the alarm condition has been rectified. If the alarm condition still exists 120 seconds after silencing the alarm buzzer, the buzzer will start to sound again.

**Note:** A low alarm condition will remain until the actual concentration is .1% higher than the low alarm setting. A high alarm condition will remain until the actual concentration is .1% lower than the high alarm setting.

## 2.6 Calibration Procedures

### 2.6.1 Calibration to 100% Oxygen







The MAXBlend™ should be calibrated before being placed into clinical use. Thereafter, Maxtec recommends calibration of the unit on a weekly basis. Frequent calibration will have no adverse effect on the performance of the MAXBlend™.

Calibration should also be performed upon replacement of a sensor or when point-of-use elevation changes by more than 500 feet or 150 meters. The sensor is best calibrated while mounted in the MAXBlend™ sensor port. As in normal operation, the oxygen sensor responds best when installed in a vertical position with the sensor facing down.

It is best to calibrate the MAXBlend™ using the sensor port, and with a technical grade oxygen standard (99.996% or better) at a pressure and flow similar to your application. Calibration of the unit at lower concentrations or with room air is less accurate over the full FiO<sub>2</sub> operating range.

1. Connect the oxygen supply line (**Pressure differential alarm may sound**). Verify the sensor is plugged into the O<sub>2</sub> sensor port and connected to the sensor cable. (**Do not connect air supply line at this time.**)



2. Using the ON/OFF key , make sure the MAXBlend™ is in the power on mode.
3. Rotate the FiO<sub>2</sub> control knob to the 100% stop. Allow a few minutes for the reading to stabilize.
  - » If LOCKED icon is displayed, press the LOCK key , the icon should disappear.
4. Press the CAL key , the text "CAL" will be displayed at the top of the screen momentarily, followed by a flashing % icon.
5. Press the up  or down  key to adjust the displayed oxygen concentration to 100.0%.
  - » After the value is set, press the CAL  or LOCK keys to return to normal operation.

**Note:** If 10 seconds elapse between key actuations, the system will store the latest calibration value and will revert to normal operation. If this occurs inadvertently, simply repeat the calibration procedure.

**Note:** If the word **CAL**, followed by the word **Er** flashes on the display after entering the desired calibration value, the system has determined that the entered value will not allow operation within the specified output range of the sensor. This situation may occur if:







- » The operator has inadvertently entered the wrong concentration for the calibration gas.
- » The concentration of the calibration gas is not correct.
- » The sensor is in need of replacement.
- » The operator attempted to adjust the monitor before allowing sufficient time for the calibration gas to purge out the previous sample.
- » The flow and pressure of the calibration gas was not properly regulated.

**Check these items and repeat calibration. If calibration error continues to occur, contact the Maxtec technical service department.**

### 2.6.2 Calibration to Room Air

The MAXBlend™ can quickly be calibrated to room air (20.9%) using a quick shortcut command. This function saves time by setting the calibration value to 20.9% without scrolling the display. To use this function:





1. Connect the air supply line (**Pressure differential alarm may sound**). Verify the sensor is plugged into the O<sub>2</sub> sensor port and connected to the sensor cable. (**Do not connect oxygen supply line at this time.**)
2. Using the ON/OFF key , make sure the MAXBlend™ is in the power on mode.

3. Rotate the FiO<sub>2</sub> control knob to the 21% stop. Allow a few minutes for the reading to stabilize.
  - » If LOCKED icon is displayed, press the LOCK key , the icon should disappear.
4. Press and CAL key , the text "CAL" will be displayed at the top of the screen momentarily which will be followed by a flashing % icon.
5. Press the up  or down  key to adjust the displayed oxygen concentration to 20.9%.
6. After the value is set, press the CAL  or LOCK key  to return to normal operation.

The unit will automatically enter the LOCKED condition and return to normal operation.

### 2.6.3 Automatic Calibration to Known Concentration

The MAXBlend™ can be quickly calibrated to the previous calibration value if a known, reliable standard is used for successive calibrations. This quick key function saves time by setting the calibration value to the last calibration value used, without scrolling the display. To use this function:

1. Introduce the previously used calibration gas to the sensor.
2. Press the LOCK key  to unlock the keypad.
3. Press and hold down the CAL Key . When the % sign starts to flash, press the up key  to set the calibration value to the primary setting.
4. Release both the CAL Key  and the up key .

**The unit will automatically enter the LOCKED condition and return to normal operation.**

**- See Cautions for Calibrating in Cautions Section**

## ❖ 3.0 Performance Check

Prior to placing the MAXBlend™ into clinical use, periodically perform the following tests.

**WARNING:** If the MAXBlend™ does not function as described on the next page, contact your Maxtec Distributor or

Maxtec®  
6526 South Cottonwood Street,  
Salt Lake City, UT 84107  
(801) 266-5300 or (800) 748-5355

DO NOT use the MAXBlend™ until correct performance has been verified.

### 3.1 Pressure Differential Alarm/Bypass Check

**Note:** Before proceeding, ensure that the high alarm set point control is OFF [display reads (--)] and that the low alarm set point control is below 20.

PROCEDURE	MAXBlend™ RESPONSE
1. Adjust the oxygen concentration such that the display reads 60%O <sub>2</sub> ±3%.	No response.
2. Disconnect the 50 PSIG AIR source from the MAXBlend.	Audible alarm sounds. Display reads <b>100% O<sub>2</sub> ±2%</b> .
3. Reconnect 50 PSIG AIR source to the MAXBlend.	Audible Alarm stops. Verify that display panel reads <b>60% ±5%</b> .
4. Disconnect 50 PSIG OXYGEN source from the MAXBlend.	Audible alarm sounds. Display reads <b>20.9%±2%</b> .
5. Reconnect 50 PSIG OXYGEN to the MAXBlend.	Audible alarm stops. Verify that display panel reads <b>60%±5%</b> .
6. Adjust both air and oxygen inlet regulators to 0 PSIG.	No response.
7. Remove air inlet hose at regulator and insert end into beaker of water.	No response.
8. Slowly raise pressure of oxygen regulator to 50 PSIG and back to 0 PSIG while observing air hose end in beaker.	No bubbles should be observed. Audible alarm sounds.
9. Dry and reattach air inlet hose to regulator.	No response.
10. Remove oxygen inlet hose at regulator, and insert end into beaker of water.	No response.
11. Slowly raise pressure of air regulator to 50 PSIG and back to 0 PSIG while observing oxygen hose end in beaker.	No bubbles should be observed. Audible alarm sounds.
12. Dry and reattach oxygen inlet hose to regulator.	No response.

## ➤ 4.0 TROUBLESHOOTING

### 4.1 Problem Troubleshooting

**Problem:** Oxygen concentration discrepancy between oxygen concentration selection knob and actual reading on display.

**Potential Causes and solutions:**

- » Monitor out of calibration. Calibrate. Refer to Section 2.6, Calibration Procedure.
- » Sensor exhausted. Replace. Refer to Section 6.2.
- » Gas supply contaminated. Contact Maxtec for repair of the MAXBlend™.
- » MAXBlend™ blender operation out of calibration. Contact Maxtec for repair.

**Problem:** Pressure Differential Alarm Sounding

**Potential Causes and solutions:**

- » Inlet pressure differences of 20 PSI or more. Correct pressure difference.
- » Pressure alarm not calibrated properly. Contact Maxtec for repair.
- » MAXBlend™ blender operation out of calibration. Contact Maxtec for repair.

**Problem:** MAXBlend™ in bypass mode, no audible pressure differential alarm.

**Potential Causes and solutions:**

- » Reed alarm cap damaged or defective. Contact Maxtec for repair.

**Problem:** Selected oxygen concentration accurate only when gas pressures are equal.

**Potential Causes and solutions:**

- » MAXBlend™ balance module not functioning properly. Contact Maxtec for repair.

**Problem:** Blank display.

**Potential Causes and solutions:**

- » Battery not installed. Install. Refer to Section 2.1.1.
- » Battery completely dead. Replace. Refer to Section 2.1.1.
- » Monitor defective. Contact Maxtec for repair.

**Problem:** Partial or distorted display.

**Potential Causes and solutions:**

Monitor damaged. Contact Maxtec for repair.

**Problem:** Sensor will not calibrate.

**Potential Causes and solutions**

- » Sensor cell exhausted. Replace. Refer to Section 6.2.
- » Sensor cable or holder defective. Return to Maxtec.
- » Monitor defective. Maxtec for repair.

**Problem:** Sensor will calibrate, but takes too long to return to 21%  $\pm$ 2% oxygen in air (2 to 5 minutes) when performing the daily check procedure.

**Potential Causes and solutions:**

» Disposable oxygen sensor damaged or defective. Replace. Refer to Section 6.2.

**Problem:** Sensor will calibrate, but does not return to 21%  $\pm$ 2% oxygen in air (2 to 5 minutes) when performing daily check procedure.

**Potential Causes and solutions:**

» Disposable oxygen sensor damaged or defective. Replace. Refer to Section 6.2

**Problem:** Sensor will calibrate, but reading at any constant level drifts more than  $\pm$ 3% over a 24 hour period.

**Potential Causes and solutions:**

» Barometric pressure change since last calibration. Recalibrate.  
» Room or gas temperature went below 59°F (15°C) or above 104°F (40°C). Correct temperature and recalibrate.

**Problem:** Sensor exhibits greater than 1% oxygen interference in the presence of gases or vapors listed in the sensor specifications.

**Potential Causes and solutions:**

» Sensor defective. Replace. Refer to Section 6.2.  
» The MAXBlend™ requires internal adjustment. Contact Maxtec for repair.

## ⚡ 5.0 CLEANING THE MAXBlend™

The MAXBlend™ should be kept clean and free of dust. The exterior of the MAXBlend™ may be cleaned with a soft cloth lightly dampened with warm soapy water or mild disinfectant. An all-purpose cleaner may be used on the MAXBlend™'s exterior. Store the MAXBlend™ in a clean, dry place when not in use.

### **Warnings:**

- » Explosion hazard. DO NOT gas sterilize the MAXBlend™.
- » Do not steam autoclave or otherwise subject the MAXBlend™ sensor to temperature over 120°F (50°C).
- » Do not immerse the MAXBlend™ or sensor into liquid decontamination agents.
- » Do not use any strong solvent cleaners on labels.

## ⚡ 6.0 SERVICE AND MAINTENANCE

### **6.1 Maintenance**

Prior to placing the MAXBlend™ into clinical use periodically follow the performance check guidelines listed in Section 3.

When using the MAXBlend™ with a medical grade compressed air source,

an air inlet watertrap/filter is recommended to be attached to the air inlet of the MAXBlend™ prior to use. Contaminants from hospital air lines may compromise the function of the MAXBlend™.

Elastomer components such as O-rings are designed to function satisfactorily for a minimum of two (2) years. Maxtec® recommends that the MAXBlend™ be overhauled and serviced at a minimum of every two (2) years under the best circumstances.

## 6.2 Replacing O<sub>2</sub> Sensor

1. Remove the sensor from the sensor monitor port.
2. Remove the sensor from the sensor cable.
3. Install a new O<sub>2</sub> sensor, taking care not to use excessive force when plugging and/or threading the mini plug into the O<sub>2</sub> sensor.
4. Calibrate the sensor following the instructions for daily calibration listed in Section 2.6.

## 6.3 Service Procedure

**CAUTION:** When disassembling, care must be exercised to prevent damaging printed circuit board. All work must be accomplished in a static safe environment.

1. Remove batteries.
2. Remove galvanic sensor from sensor port and disconnect from coiled cable.
3. Using a 11/16 inch wrench, remove bottom port connector. Exercise caution as bottom outlet block is attached by this connector. Remove and discard three (3) o-rings from connector. Remove and discard sensor port bleed muffler from bottom outlet block by carefully prying out ringclip. Set block and connector aside for cleaning and reassembly.
4. Using a proper screwdriver (Phillips), remove four (4) cross-recessed screws holding front bezel to main case. Carefully pull front bezel forward and disconnect red and black cables from the battery case. Set all parts aside for reassembly.
5. Neither the circuit board or keypad are serviceable. If it determined that the keypad or circuit board are defective, with proper screwdriver (Phillips) remove four (4) cross-recessed screws holding the circuit board to front bezel. Package the keypad and circuit board carefully in proper static safe materials and return to Maxtec®.
6. Contact Maxtec® for a Returned Authorization Number (RA#) prior to sending the unit in for service.
7. Using a hex wrench, remove the two (2) hex screws from the rear of the case. Exercise caution as the MicroBlender will be loose and is heavy. Slide the Microblender out from the case and set the two (2) screws aside for reassembly.

## MAXBlend Low Flow Model

The Microblender is now serviceable as a 3920 Low Flow Micro Blender. The 3920 Micro Blender must be serviced by Viasys factory certified technicians. Please contact Maxtec for proper return, cleaning and/or service instructions.

## 7.0 ABBREVIATION GUIDE

Term	Description
Air/O <sub>2</sub>	Mixture of compressed air and oxygen
°C	Degrees celsius
CGA	Compressed Gas Association
DISS	Diameter Indexed Safety System
°F	Degrees fahrenheit
FiO <sub>2</sub>	Fractional Concentration of Inspired Oxygen
O <sub>2</sub>	Oxygen
LPM	Liters Per Minute
PSIG	Pounds Per Square Inch Gauge

## 8.0 SPECIFICATIONS

### 8.1 Low Flow Instrument Specifications

Weight (unpackaged)	4.5 lbs. (2 kg.)
Power Source	Two (2) AA alkaline batteries, 1.5 V each
Battery Life	3000 hours (continuous operation, no alarming)
Oxygen Measurement Range	0% to 100% oxygen
Display Resolution	0.1% oxygen
O <sub>2</sub> Concentration Adjustment Range	21% to 100% O <sub>2</sub>
Gas Supply Pressure	30-75 PSIG (2.0 to 5.2 BAR) (air and oxygen must Range be within 20 PSI (1.3 BAR) Do not operate the blender outside the supply pressure range (30-75 PSIG). Do not operate unit between 0 and 30 PSIG or above 75 PSIG supply pressures. Optimal performance is with gases at 50 PSIG nominal.
Pressure Drop	Less than 6 PSI (0.4 BAR) @ 50 PSIG (3.4 BAR) supply pressures and 10 LPM flow rate
Bleed Flow	2.5-3.5 LPM @ 50 PSIG (3.4 BAR)
Outlet Flow Range	0-30 LPM with supply pressures at 50 PSIG (3.4 BAR) air and 50 PSIG (3.4 BAR)O <sub>2</sub>
Mixed gas Stability* Ambient Operating Conditions	±1% oxygen
Temperature Range	59°F to 104°F (15°C to 40°C)
Relative Humidity Range	0-95%, non-condensing
Ambient Storage Conditions Temperature Range	5°F to 122°F (-15°C to 50°C)

\*The delivered oxygen concentration will remain constant within ±1% of the set point value with constant inlet pressures. The displayed value may vary more than this due to sensor accuracy, age, environmental conditions and length of time since last sensor calibration.

### 8.2 Alarm Specifications

Pressure Differential Alarm Activation	When supply pressures differ by 20 PSI (1.3 BAR) or more Activation
--	---

High Low Concentration Alarm Range . . . . . 15% to 99% oxygen

### 8.3 O2 Sensor Specifications

Total Accuracy: . . . . .  $\pm 3\%$  actual oxygen level over full operating temp range  
Oxygen Measurement Accuracy . . . . .  $\pm 2\%$  oxygen  
Linearity . . . . .  $\pm 1\%$  oxygen when temperature and pressure are held constant  
Potential Error Due to  
Change in Sensor Temperature . . . . .  $\pm 3\%$  oxygen, maximum  
Response Time to 90% of Final Reading . . . . . @ 77°F (25°C)  $\leq 20$  seconds  
Ambient Operating Temperature Range . . . . . 59°F to 104°F (15°C to 40°C)  
Ambient Operating Humidity Range . . . . . 0% to 95% (non-condensing)  
Ambient Storage Temperature Range . . . . . 5°F to 122°F (-15°C to 50°C)  
Monitored Gas Temperature Range . . . . . 59°F to 104°F (15°C to 40°C)  
Monitored Gas Humidity Range . . . . . 0% to 95% (non-condensing)  
Expected Useful Life . . . . . 1,500,000 O2 % hours (approx. 2 years average use)  
Sensor “Warm Up” Time . . . . . One minute, nominal time required after the  
initial installation of sensor before specifications are applicable.

**Note:** All specifications assume the following standard environmental conditions unless specified otherwise.

- » Ambient and sample gas temperatures of 77°F (25°C)
- » Barometric pressure of 30 in. of Hg (760mm Hg)
- » Ambient relative humidity of 50%
- » Sample gas relative humidity of 0%

## 9.0 FACTORS INFLUENCING CALIBRATION

### 9.1 Temperature Effect

The MAXBlend™ will hold calibration and read correctly within  $\pm 2\%$  when in thermal equilibrium within the operating temperature range. The device must be thermally stable when calibrated and allowed to thermally stabilize after experiencing temperature changes before readings are accurate. For these reasons, the following is recommended:

- » Allow adequate time for the sensor to equilibrate to a new ambient temperature.
- » When the sensor is placed in a breathing circuit use a “T” adapter and place the sensor upstream of the heater.
- » For best results, perform the calibration procedure at a temperature close to the temperature where analysis will occur.

### 9.2 Pressure Effect

Readings from the MAXBlend™ oxygen monitor are proportional to the partial pressure of oxygen. The partial pressure is equal to the concentration times of the absolute pressure. Thus the readings are proportional to the concentration if the pressure is held constant. Flow rate of sample gas can affect pressure at the sensor due to a change in back pressure at the sensing point. For these reasons, the following is recommended:

- » Calibrate the MAXBlend™ at the same pressure as the sample gas.



- » When the sensor is placed in a breathing circuit using a “T” adapter, use the same flow rates when calibrating as when measuring.
- » The MAXBlend™ oxygen sensor has been validated at pressures up to 2 atmospheres absolute. Calibration or operation above this pressure is beyond the intended use.

## 9.2 Humidity Effect

Humidity has no effect on the performance of the MAXBlend™ oxygen monitor other than diluting the gas, as long as there is no condensation. Depending on the humidity, the gas may be diluted by as much as 4%, which proportionally reduces the oxygen concentration. The device responds to the actual oxygen concentration rather than the dry concentration. Environments where condensation may occur are to be avoided since condensate may obstruct passage of gas to the sensing surface, resulting in erroneous readings and slower response time. For this reason, the following is recommended:

- » Avoid usage in environments greater than 95% relative humidity.
- » When the sensor is placed in a breathing circuit using a “T” adapter, place the sensor upstream of the humidifier.

## ⚙️ 10.0 SPARE PARTS AND ACCESSORIES

<b>Description</b>	<b>Part Number</b>
MAXBlend™ Low Flow	R203P05-001
MAXBlend™ Low Flow w/NIST Inlet Fitting	R203P05-002
MAXBlend™ Low Flow w/ French/AFNOR Fittings	R203P05-003
MAXBlend™ Low Flow (International) w/NIST Inlet Fitting	R203P05-004
MAX250E Oxygen Sensor	R125P03-002
Manual (English)	R203M06-003
Manual (International)	R203M06-014

### Accessories

<b>Description</b>	<b>Part Number</b>
Monitor Cable	R103P16
“T” Adapter (15 mm ID)	RP16P02
Rail Mount Bracket	R100P09
Adjustable Wall Mount Bracket	R100P16
Adjustable Pole Mount Bracket	R100P22
Pole Mount Bracket	R100P26
Accessory Hook	R200P03
Compact Wall Mount	RP05P07
Air Inlet Filter/Water Trap	RP05P08
Wall Mount Large Bracket	RP05P09
10' Dual Blender hose (DISS)	R129P01
2' Blender hose (DISS)	R129P12
Blender Buddy	R211P11

For additional accessory information please contact Maxtec®, Customer Service at: (801) 266-5300 or (800) 748-5355.

## ✶ 11.0 Theory of Operation

### 11.1 Operational Diagram

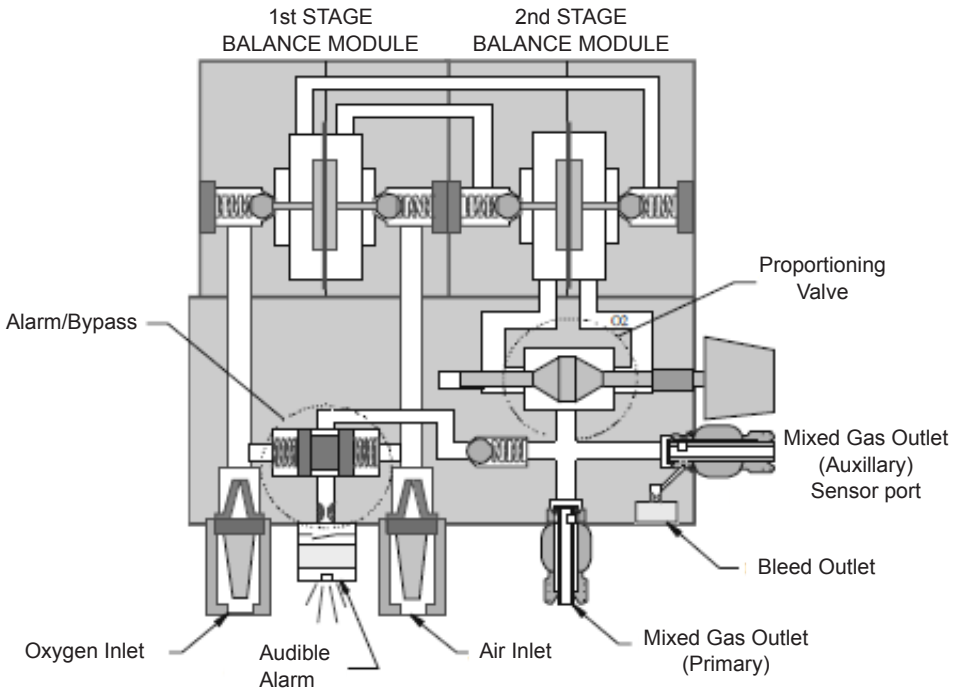

### 11.2 Mixing Operation

The MAXBlend™ is designed to utilize two (2) 50 PSIG (3.4 BAR) gas sources. The two (2) gas sources enter through the air and oxygen inlet connectors located on the bottom of the MAXBlend™. Each inlet connector incorporates a 30 micron particulate filter. Once through the filters, each gas passes through a duckbill check valve, which prevents possible reverse gas flow from either the air or the oxygen supply systems.

The two (2) gases then pass through a two-stage balance regulator. The purpose of this regulator is to equalize the operating pressures of the air and oxygen gas sources. Once these pressures have been balanced, the gases are proportioned according to the oxygen concentration selected on the oxygen concentration selection knob. The oxygen concentration knob allows the clinician to select a desired oxygen concentration from 21% to 100% O<sub>2</sub>. From this point, the mixed gas flows to the outlet port.

### 11.3 Gas Outlet

There are two (2) gas outlets on the MAXBlend™: one on the bottom of the unit and one on the left side (See Page 4). These outlets are capable of delivering combined metered flows of 0-30 liters per minute (LPM) for the MAXBlend Low Flow Model of mixed gases. These outlet ports are fitted with an automatic shut off valve. The flow of gas from either outlet port is automatically initiated by attaching a pneumatic device (such as a flowmeter) to the outlet port. Regardless of whether or not the outlet has any device connected to it, a minimal gas bleed flow of 2.5-3.5 LPM flows for the MAXBlend Low Flow Model from the sensor port on the right side of the blender. It is from this bleed flow that the gas is sampled and analyzed by the MAXBlend™ analyzer and monitor functions.

## 11.4 Alarm/Bypass Function

The MAXBlend™ includes a pressure differential alarm which provides an audible alarm if gas source pressures differ by 20 PSI (1.3 BAR) (nominal) or more, or if there is a gas supply failure of one of the source gases. This alarm is generated by a reed alarm located in a cap on the bottom of the MAXBlend™. The primary purpose of the alarm is to audibly warn the operator of an excessive pressure drop or depletion of either source gas pressure. The alarm will also activate when there is an elevation of either source gas pressure resulting in a differential of 20 PSI (1.3 BAR)(nominal) or more. Should both gas pressures increase or decrease simultaneously, an alarm will not activate. If either source gas pressure drops, the outlet pressure will drop similarly as the mixed gas is always balanced to that of the lower gas source.

The gas bypass function operates in unison with the alarm. Once the pressure alarm is activated, the bypass function is actuated and the gas with the higher pressure flows directly to the outlet port, bypassing the mixing function of the MAXBlend™. The oxygen concentration flowing out of the MAXBlend™ will be that of the gas with the higher pressure. The MAXBlend™ in the pressure alarm/bypass mode will deliver oxygen (100%) or medical air (21%) until pressures have been restored to a differential of 6 PSI (.4 BAR). If the MAXBlend™ is set to deliver 21% and the OXYGEN source pressure is reduced enough to produce a 20 PSI (1.3 BAR) differential, the unit may not alarm because it will continue to deliver 21% concentration according to the setting. If the setting is moved slightly from 21%, the pressure differential alarm will sound. Similarly, if the MAXBlend™ is set to deliver 100% and the AIR source pressure is reduced or lost, the unit may not alarm because it will continue to deliver 100% concentration.

## ⚙️ 12.0 Flow Characteristics

The outlet pressure of the MAXBlend™ decreases as the total flow rate increase. The total flow rate is the measurement of the total flow from both outlet ports. The 1st chart below indicates the pressure drop that occurs for the low flow model at 3 inlet pressure settings; 30 psi (2.07 bar), 50 psi (3.45 bar), and 75 psi (5.17 bar). The second chart below indicates the average outlet flow at various inlet pressures.

### Flow Rate -vs- Typical Pressure

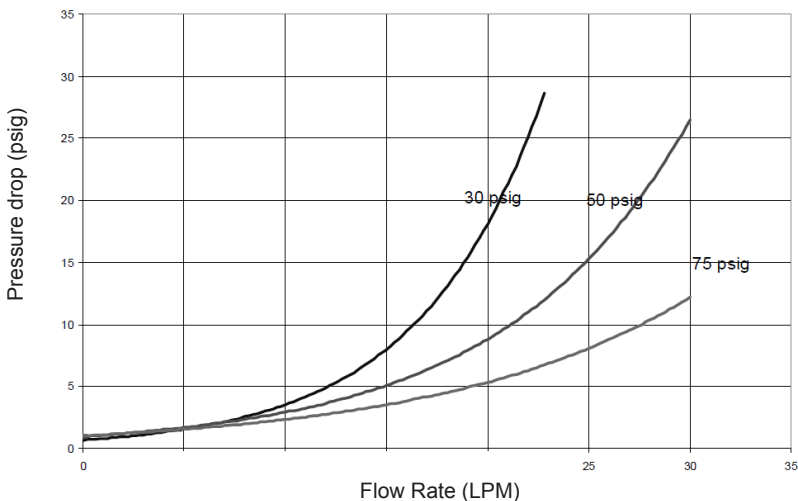

# Flow -vs- Inlet Pressure

